



Vyntus® ONE

all-in-one system for pulmonary function and cardiopulmonary stress testing

Vyntus[®] ONE

Technical specifications

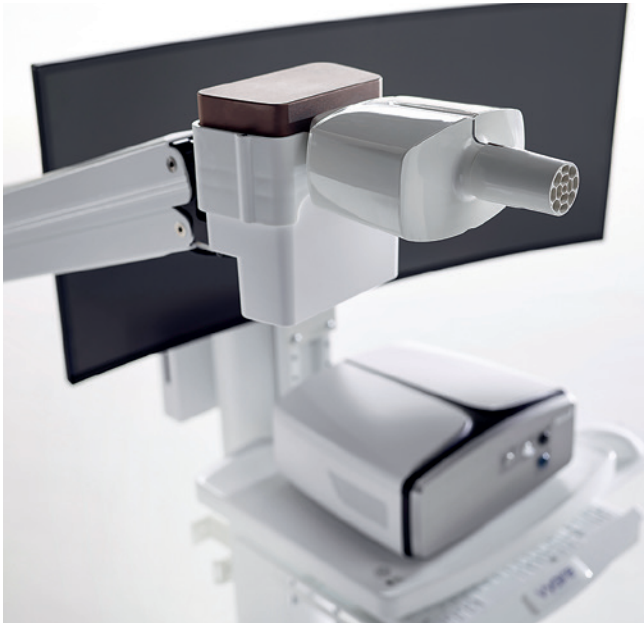

Vyntus ONE with ultrasonic flow sensor and eDemand valve for pulmonary function testing



Vyntus ONE with DVT and option Vyntus[®] ECG for cardiopulmonary exercise testing

Measurement	
Dynamic lung volumes:	FVC, FEV1, FEV1/FVC, MFEF 25-75, FEF 75, PEF and others
Static lung volumes:	Absolute lung volumes: TLC, FRCN2, RV, RV/TLC and others
	Static lung volumes: VC IN, VC EX, VC MAX, IC, ERV and others
	Lung homogeneity: LCI (lung clearance index)
CO-diffusion real-time and CO-diffusion intra-breath:	DLCO, KCO, VA, TLC, FRCSB, RV and others
Cardiopulmonary-exercise-testing:	V'O ₂ , V'CO ₂ , RER, V'O ₂ /kg, V'E, BF, VTex, EqO ₂ , EqCO ₂ , BR FEV%, PETO ₂ , PETCO ₂ , REE, FAT, CHO, PROT and others
Options:	<ul style="list-style-type: none"> - Respiratory muscle strength (MIP/MEP) - Respiratory muscle strength (SNIP) - Respiratory drive (P0.1) - Airway resistance (Rocc/Rint) - Rhinomanometry - Compliance - Body plethysmography - Resting ECG - Stress ECG - SpO₂
Components	
<ul style="list-style-type: none"> • Vyntus ONE module with fast reliable gas analyzers and container for easy O₂ cell replacement • Calibration-free and waterproof ultrasonic flow sensor • Easy-to-clean Flow Path Valve with eDemand valve for test gas supply • Digital Volume Transducer (DVT) for the exact CPET ventilation measurement • PC with hygiene keyboard/mouse, printer and flatscreen monitor. • Ergonomic, smooth-running cart with optional height adjustable keyboard/mouse drawer, isolation transformer and flexible 3D arm. • Set of accessories • Complete software package for measurement and report generation plus extended infrastructure for data management 	

Required space

Vyntus ONE with CART 3.0N/3.1N:

Space requirements: 120 × 150 cm (excluding operator and patient)

Vyntus ONE with CART 3.0N/3.1N and Vyntus BODY:

Space requirements: 140 × 260 cm (excluding operator and patient)



Vyntus ONE with height adjustable (optional) CART 3.1N

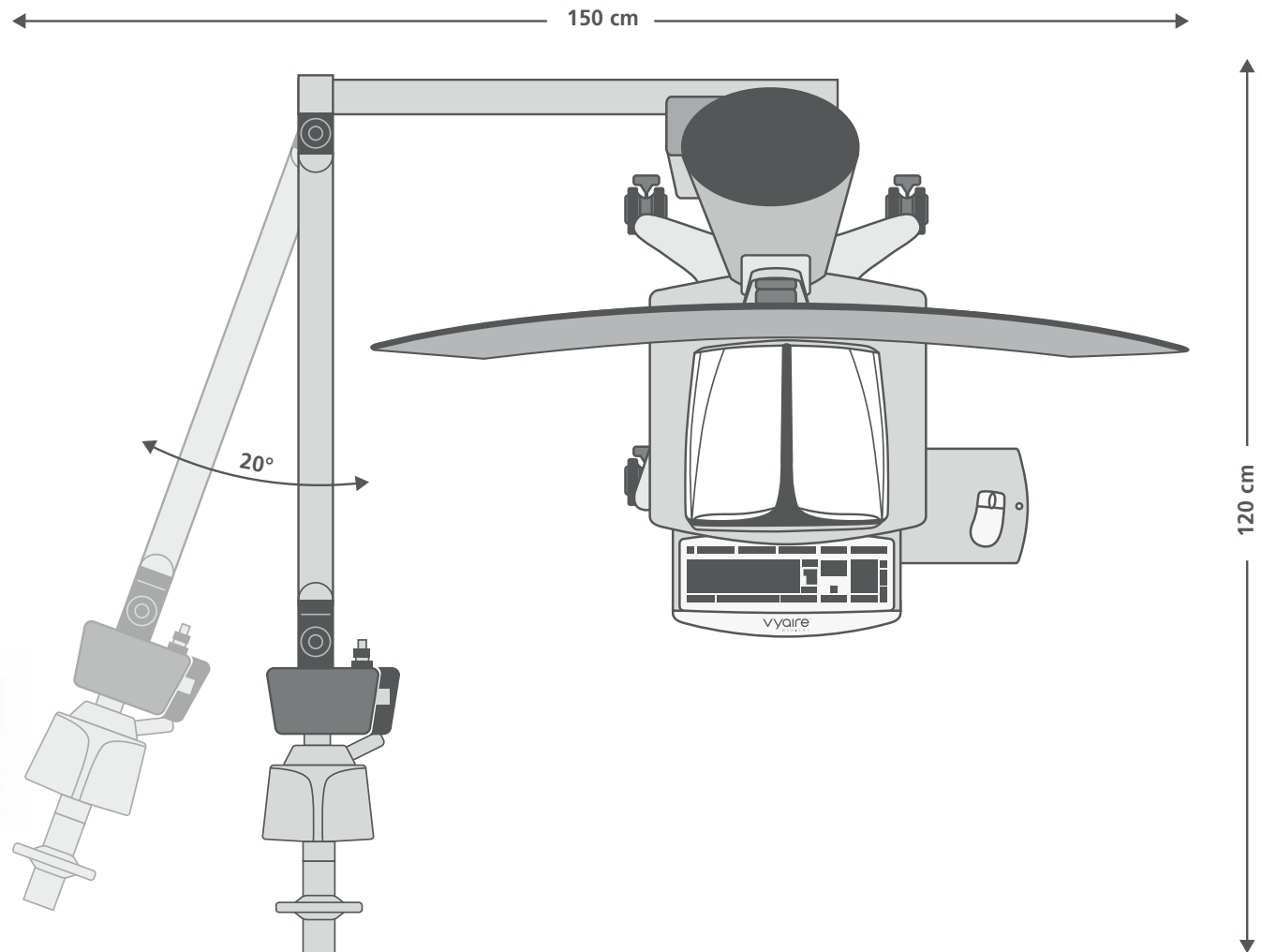



Calibration-free and waterproof ultrasonic sensor



Vyntus ONE fits all kind of patients – also the little ones

Ultrasonic flow sensor – PFT application

Flow measurement

Type	Ultrasound
Methodological peculiarities	Simultaneous measurement of ultrasound transit time in and against flow direction
Sample rate	True 1000 Hz for flow, achieved by 2000 ultrasound transit time measurements (double shot technology)
Range	0 to 18 L/s bidirectional
Accuracy	Exhalation 0 to 14 L/s: 1.5% or 0.05 L/s (whichever is greater) Inhalation 0 to 14 L/s: 2.0% or 0.05 L/s (whichever is greater)
Precision	1% or 0.1 L/s (whichever is greater)
Resolution	0.001 L/s
Total resistance (MicroGard II filter + USS Module + FPV block eDemand)	<0.150 kPa*s/L (<1.53 cmH ₂ O*s/L) at 14 L/s
Dead space USS Module	66 mL

Volume integration

Principle	Software volume integration of flow signal (ultrasound)
Range	30 L (software limited)
Accuracy	Exhalation and inhalation 0.5 to 14 L/s: 2.5% or 0.075 L (75 mL)
Precision	1% or 50 mL (whichever is greater)
Resolution	0.001 L

Mouth pressure measurement

Type	piezo resistive
Range	± 30 kPa (±225 mmHg)
Accuracy	0 to ±2 kPa: ± 2% or 0.02 kPa (0.150 mmHg) (whichever is greater)
Resolution	0.001 kPa (0.0075 mmHg)

O₂ analyzer

Type	Fully digital, high speed analyzer, based on electrochemical principle
Measurement	0 – 100 vol%
Accuracy	0.05 vol% or 0.2%
Resolution	0.01 vol%
Typical rise time (T10 – 90)*	75 ms
Service life	Typically 2 years

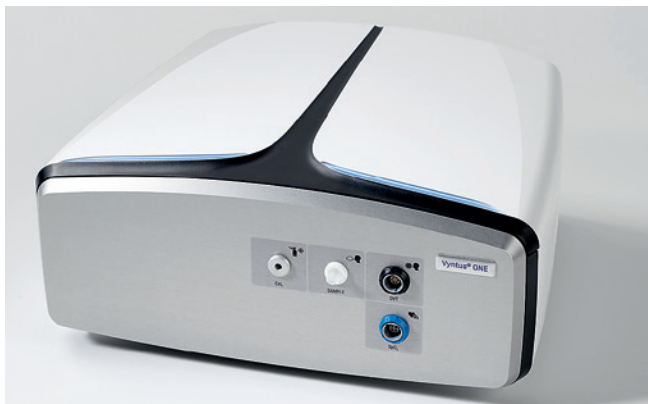

Vyntus ONE main unit equipped with all PFT and CPET gas analyzers



Vyntus ONE CPET application with bike or treadmill



Digital Volume Transducer (DVT) for the exact CPET ventilation measurement

CO₂ analyzer

Type	Fully digital, high speed analyzer, based on infrared absorption
Measurement	0 – 15 vol %
Accuracy	0.05 vol % or 1%
Resolution	0.01 vol %
Typical rise time (T10 – 90)*	75 ms

* Rise time after digital filtering. During every gas calibration the filter coefficients are specifically optimized for the sensors.

Multigas analyzer (CO/CH₄/C₂H₂) – Diffusion measurement

Type	Infrared
Range	0 – 0.4 vol %
Accuracy	0.003 vol % or 2% relative (whichever is greater)
Resolution	0.0005 vol %
Maximum nonlinearity:	1% of full scale
Response time	≤145 ms

Gas exchange CPET (*physiological measurement*)

Parameter	Measurement range	Accuracy
Ventilation (V'E)	0 to 300 L/min	2% or 0.5 L/min
O ₂ uptake (V'O ₂)	0 to 7 L/min	3% or 0.05 L/min
CO ₂ production (V'CO ₂)	0 to 7 L/min	3% or 0.05 L/min
RER	0.6 to 2.0	4% or 0.04

Volume sensor CPET DVT (*physiological measurement*)

Type	Flat vane system	
Weight	45 g	
Dead space	30 mL	
Resolution	3 mL	
Resistance	< 0.1 kPa/L/s (0.75 mmHg/L/s) at 15 L/s	
ATS	Compliant	
Parameter	Measurement range	Accuracy
Volume	0 – 10 L	2% or 0.05 L
Flow	0 – 15 L/s	3% or 0.07 L/s

Ambient measurement

Sensor	Measurement range	Accuracy
Temperature sensor	-10 to 50 °C (14 to 122 °F)	±0.5 °C at 20 °C (68 °F) ±1 °C at 10 to 34 °C (50 to 93.2 °F)
Humidity sensor	0 – 100% relative humidity	4% relative humidity at 20 – 80% relative humidity
Air pressure sensor	500 to 1100 hPa (375 to 825 mmHg)	±2.5 hPa (1.88 mmHg) at 700 to 1060 hPa (525 to 795 mmHg)

SpO₂ sensors

Displayed oxygen saturation range (SpO ₂)	0 to 100 %
Displayed pulse rate range	18 to 321 beats per minute (BPM)
SpO ₂ accuracy (Arms*)	±3 digits @ 70 to 100 %

* ±1 Arms represents approximately 68% of measurements.

Vyntus ECG

Application	ECG recording	
ECG leads	According to Einthoven, Wilson, Goldberger	
Bandwidth	0.05 – 150 Hz digital	
Sampling rate per channel	500 Hz	
Pacemaker detection	4000 Hz	
Resolution	< 2.5 µV/bit	
Connection to the PC	Wireless, Bluetooth®	
Connection of the electrodes	4 mm snap, gilded or suction electrode	
Bluetooth®	Bluetooth® module	Panasonic PAN 1322
	Bluetooth® standard V2.1, class 2 device	V2.1, class 2 device
	Output power	2.5 dBm, max. 4.5 dBm
	Frequency range	2400 – 2483.5 MHz
	FCC identifier	T7VEBMU
	IC identifier	216QE BMU
	Bluetooth® QD ID	B021246

Calibration syringe

Volume	3 L
Accuracy	± 0.4 %

Keyboard / Mouse

Medical keyboard	Kind of disinfection	Wipe disinfection
	Material	Silicone key membrane / sealed key field
Hygiene mouse	Kind of disinfection	Wipe disinfection
	Protection class	IP68 fully sealed

MicroGard™ II Series:

Inspiratory resistance	< 0.4 cm H ₂ O/L/s at 1 L/s
Expiratory resistance	< 0.4 cm H ₂ O/L/s at 1 L/s
Filtering efficiency against cross contamination	Bacterial: > 99.999 % (based on Nelson Lab test)
	Viral: > 99.999 % (based on Nelson Lab test)
Filter volume	55 mL, including adapters and housing
Connections	30 mm ID. 30 mm OD. Tapered ports
Connections (filter with integrated mouthpiece)	30 mm ID. Tapered port
Application	Single patient use
Material	Latex-free product
Hygiene cycle for downstreamed parts	3 months (based on Bio Burden DIN EN ISO 11737-1: Report 18AA0088)

Pressure reducer

Diffusion gas		
Inlet pressure	200 bar	
Outlet pressure	7 bar (fixed)	
Flow rate	at least 500 L/min	
Outlet	G 1/4 internal screw thread	connector for tube with ID 8 mm

O₂ gas

Inlet pressure	200 bar	
Outlet pressure	3 bar (fixed)	
Flow rate	at least 120 L/min	
Outlet	G 1/4 internal screw thread	connector for tube with ID 6 mm

Calibration gas

Inlet pressure	200 bar	
Outlet pressure	2 bar (fixed)	
Outlet	G 1/4 internal screw thread	connector for tube with ID 3 mm

Gas concentrations

Diffusion gas

Methane (CH ₄)	0.3% ± 0.021%
Carbon Monoxide (CO)	0.3% ± 0.021%
Acetylene (C ₂ H ₂) (optional)	0.3% ± 0.021%
Oxygen (O ₂)	21% ± 1.47%
Nitrogen	Rest

Oxygen O₂ gas

Oxygen (O ₂), medically pure	100%
--	------

Calibration gas

Oxygen (O ₂)	16% ± 0.8%
Carbon dioxide (CO ₂)	5% ± 0.3% with accuracy of 1% (relative)
Methane (CH ₄)	0.3% ± 0.021%
Carbon Monoxide (CO)	0.3% ± 0.021%
Acetylene (C ₂ H ₂) (optional)	0.3% ± 0.021%
Nitrogen	Rest

Dimensions / Weight

Vyntus ONE module

Dimensions	33 cm W × 28.5 cm D × 13.5 cm H (13" × 11.2" × 5.3")
Weight	3.99 kg (8.796 lbs)

Vyntus CART 3.0N/3.1N

Dimensions total	145 cm W × 118 cm D × 175 cm H (57.1" × 46.5" × 68.9")	
Weight total	71 kg (156.5 lbs) inclusive 24" Monitor	
Castors	4 twin swivel castors Ø 10 cm (3.9"), lockable, non marking grey polyurethane tyred	
Shelves	Number	2
	Platform area	45 cm W × 36 cm D (17.7" × 14.2")
	Load capacity	20 kg (44 lbs) distributed load
Keyboard drawer with mousepad (left/right)	Keyboard platform area	40 cm W × 20 cm D (15.7" × 7.9")
	Load capacity	3 kg (6.6 lbs) distributed load
Mechanical height adjustment for keyboard/mouse and monitor (CART 3.1N only)	Type	Gas spring
	Range	30 cm (11.81")
	Load capacity during height adjustment	10 – 16 kg (22 – 35.2 lbs)

Vyntus CART 3.0N/3.1N (continued)

Computer holder for Dell OptiPlex Micro on the backside	Size inside	3.6 cm W × 17.8 cm D × 18.2 H (1.4" × 7.0" × 7.2")
	Load capacity	1.5 kg (3.3 lbs)
Monitor mount	Load capacity	8.5 kg (18.7 lbs)
	Compatible with	VESA 75 and 100
34" curved monitor as dual screen application (option)	Dimensions	ca. 82.5 cm W × 8.8 cm D × 36.1 cm H (32.5" × 3.5" × 14.2")
	Weight	ca. 6.2 kg (13.7 lbs)
Dual gas bottle mount (option)	Load capacity	2 × 6.5 kg (14.3 lbs)
	Bottle diameter	max. 111 mm

Vyntus ECG

ECG housing	Dimensions	9.5 cm W × 8.5 cm D × 2 cm H (3.7" × 3.3" × 0.8")
	Weight	0.2 kg (0.4 lbs)
Length of electrode cables	V1 – V6	60 cm (23.6")
	LL	45 cm (17.7")
	LA / RL	70 cm (27.6")
	RA	80 cm (31.5")

Ambient conditions

Temperature	+10 °C to +34 °C (+50 °F to 93.2 °F)
Relative humidity	20 to 80% RH, non-condensing
Ambient pressure	700 to 1060 hPa (600 to 795 mmHg)
Altitude	≤ 3000 m (9842 ft)

Transport and storage conditions

Temperature	– 20 °C to +50 °C (– 4 °F to 122 °F)
Rel. humidity	15 to 95% RH, non-condensing
Ambient pressure	600 to 1200 hPa (450 to 900 mmHg)

Power supply

Vyntus ONE main unit

Mains voltage	The Vyntus ONE is supplied by the isolating transformer of the Vyntus CART
Power input	max. 80 VA
Electrical safety	Protection class I

Vyntus CART 3.0N and 3.1N with PC/Monitor/Printer

Mains voltage	115 V AC/230 V AC, 50/60 Hz
Power input	690 VA
Electrical safety	Protection class I
Mains plug	Used for isolating all poles simultaneously from supply mains
Primary Fuse 230 V	2 × T3.15 A L / 250 VAC
Primary Fuse 115 V	2 × T6.3 A L / 250 VAC

Vyntus ECG

Supply voltage	1.5 V DC AA battery or 1.2 V DC AA NiMH rechargeable battery, at least 2500 mAh
Power input (max.)	500 mA
Service life with fully charged battery	at least 6 hours

Moisture Protection

Vyntus ONE	IP 20
Ultrasonic sensor (USS Module)	IP 67
Vyntus CART 3.0N / 3.1N	No IP protection
Vyntus ECG	IP 20

Classification of applied parts

Vyntus ONE	Applied Part Type B
Vyntus ECG	Applied Part Type CF, defibrillator proof

Category according to MDD 93/42/EEC (2007)

Complete system	Active class IIa medical product
-----------------	----------------------------------

Operating mode

Complete system	Continuous operation
-----------------	----------------------

Standards, directives and market clearances

Standards	EN 60601-1, EN 60601-1-2, EN 60601-2-25 (for Vyntus ECG only) ,EN 62304, EN 62366, EN ISO 14971, EN ISO 10993-1
Directives	93/42/EEC amended by 2007/47/EC, RoHS 2011 / 65 / EU compliant
Market clearances	CE, FDA 510(k) clearance

Software

Measurement Programs	Vyntus ONE DL	Vyntus ONE PFT	Vyntus ONE
Slow/Forced Spirometry/MVV	✓	✓	✓
Spirometry Animation Programs for Forced Spirometry	✓	✓	✓
Single-Breath Diffusion Real-time	✓	✓	✓
Single-Breath Diffusion Intrabreath	✓	✓	✓
Noninvasive Cardiac Output C ₂ H ₂ *	○	○	○
Lung Volumes FRC N ₂ Washout and LCI	–	✓	✓
Airways Resistance by R Occlusion	○	○	○
P 0.1	○	○	○
MIP / MEP	○	○	○
SNIP	○	○	○
Rhinomanometry	○	○	○
Compliance	○	○	○
Body plethysmography with Vyntus BODY	○	○	○
CPET breath by breath	–	–	✓
Resting ECG with Vyntus ECG	○	○	○
Stress ECG with Vyntus ECG	○	○	○
CardioSoft ECG GE Healthcare	–	–	○

* Not available for the US

Calibration Programs	Vyntus ONE DL	Vyntus ONE PFT	Vyntus ONE
Volume verification for the USS Module	✓	✓	✓
Volume calibration for the DVT (CPET)	–	–	✓
Gas calibration for all gases	✓	✓	✓

Legend: ✓ = standard | ○ = option | – = not possible

Software			
Organization Programs	Vyntus ONE DL	Vyntus ONE PFT	Vyntus ONE
SentrySuite® home page (Settings, Export/Import)	✓	✓	✓
SentrySuite Review	✓	✓	✓
Patient Data	✓	✓	✓
Report Output (Print, View, Quick View, Save, PDF)	✓	✓	✓
Multiformat Output (JPG, TIFF, RTF and others)	✓	✓	✓
Auto Interpretation	✓	✓	✓
ATS / ERS Quality Check	✓	✓	✓
Comments / Physician Interpretation	✓	✓	✓
Report Designer for generating customized reports	✓	✓	✓
Predicted Values / Reference Sets Design / Editor	✓	✓	✓
Bronchial Challenge Generation	○	○	○
CPET Layout Editor	–	–	✓
CPET Profile Editor	–	–	✓
User Parameter Editor for customized parameters	○	○	○
Offline Data Input	✓	✓	✓
SentrySuite (SeS) Quality Management	✓	✓	✓
Log file viewer	✓	✓	✓
Backup/Restore	✓	✓	✓
InterConnectivity Manager for interface with JLAB / Vmax / SPCS platforms	✓	✓	✓
GDT connection (German standard)	✓	✓	✓
Questionnaire Designer for customized questionnaires	○	○	○
SeS Q Remote Tablet Questionnaire	○	○	○
Security and User Administration	○	○	○
SentryConnect for HIS integration via HL7	○	○	○
Spirometer Data Transfer (FlowScreen®, SpiroPro®, MicroLoop, MicroLab)	✓	✓	✓
Bloodgas Data Transfer	○	○	○
SeS SQL Database Interface Query / DataCube	○	○	○
Patient Data Management for advanced corrective actions	○	○	○
Networking	○	○	○
SentrySuite Mobile Review Web Application	○	○	○

Legend: ✓ = standard | ○ = option | – = not possible



GLOBAL HEADQUARTERS

Vyairē Medical, Inc.
26125 North Riverwoods Blvd
Mettawa, IL 60045
USA



Vyairē Medical GmbH
Leibnizstrasse 7
97204 Hoechberg
Germany

AUSTRALIAN SPONSOR

Vyairē Medical Pty Ltd
Level 5, 7 Eden Park Drive
Macquarie Park, NSW, 2113
Australia



[vyairē.com](https://www.vyairē.com)

For Australia, Canada, Colombia, EU, Kuwait, New Zealand, Switzerland and Turkey distribution only.

Where applicable – country availability is dependent on the successful product registration with the National Authority of that country.

Vyairē pursues a policy of continued improvement in design, production and performance of its products.

The right is therefore reserved to vary details at any time and without notice. Trademarks are the property of their respective owners.

© 2020 Vyairē. Vyairē, the Vyairē logo and all other trademarks or registered trademarks are property of Vyairē Medical, Inc., or one of its affiliates. Medical devices class IIa according to Medical Devices Directive 93/42/EEC. Please read the complete Instructions For Use that come with the devices or follow the instructions on the product labelling. | VYR-INTL-1900025 (3.0)